

# Concrete Admixture Technology

ZIBO BNT Technology Co., Ltd.

# Company Profile

ZIBO BNT Technology Co., Ltd. as a high-tech enterprise in Shandong province, BNT provide the most advanced technology and products at all time.

To meet the needs of the customers with our excellent service is our best wish and supreme pursue.

- "AAA credit enterprise",
- Obtained ISO9001 Quality Management System certification, has a number of national patents.
- "Baote" trademark was awarded as the famous trademark of Shandong Province.



**20 hectares**

Factory covers an area

**50,000 square meters.**

Production workshop covers an area



## Business Scope

We can provide you with professional production equipment, mature synthesis process, as well as high-quality raw materials and accessories, and late application of technical support. We can provide you with professional production equipment, mature synthesis process, as well as high-quality raw materials and accessories, and late application of technical support.



- Polycarboxylic acid equipment
- Aliphatic equipment
- Concrete admixture equipment
- Production process
- Automation control system design
- Construction and commissioning
- Mechanical equipment production and installation
- Synthesis technology transfer
- Production guidance

## Our Customers

Products are exported to the United States, Brazil, South Africa, India, Thailand, Indonesia, South Korea, Japan and other more than **20** countries and regions in the world.

# NO. 1

Export sales  
by industry ranking



## Qualification and Certification

The company holds national Class I and Class II pressure vessel manufacturing qualifications, American ASME U steel seal license, passed ISO9001 quality management system certification, and has a number of national patents.





01 Rich experience and strong technology



02 Group advantage-  
The capacity to resist risks and market competitiveness.



03 Perfect after-sales service and professional technical support



## 1 / Polycarboxylate superplasticizer

Polycarboxylic acid superplasticizer principle:

Polycarboxylic acid superplasticizer is the latest generation of high performance superplasticizer, which can really design effective molecular structure according to the action mechanism of dispersed cement.

- Hyperdispersion
- High Slump Retention
- Wide Adaptability Of Cement large
- Freedom Of Molecular Structure
- Many Synthesis Techniques large
- Room For High Performance

01

In the application of concrete construction, it shows very good workability, good strength development, excellent durability, good comprehensive technical performance advantages and environmental protection characteristics.

02



Polycarboxylic acid superplasticizer is a polyether compound obtained by polymerization of macromonomer initiator, chain transfer agent, etc. The whole production process is completed in a reactor.

03

## 2 / Automatic control solutions

The production line and auxiliary engineering controlled by DCS

### Distributed control System (DCS)



01

Centralized monitoring operation, intuitive and clear, good system expansibility, easy to change the control scheme, high reliability, small maintenance,

02

Easy to connect with the host computer to optimize the management of the whole plant,

03

With rich storage functions, easy to record various data, provide analysis basis.

## 3 / System operation description

### Germany Siemens control system

Easy to achieve distributed configuration and cost-effective, strong electromagnetic compatibility, excellent shock resistance performance.

### Full control of metering system valve system, safety system

such as feed, temperature control, drip control, feed control, discharge, liquid level exceeded alarm, equipment damage alarm, emergency shutdown.

### Automatic report generation

The system automatically records the production history and generates the production report.

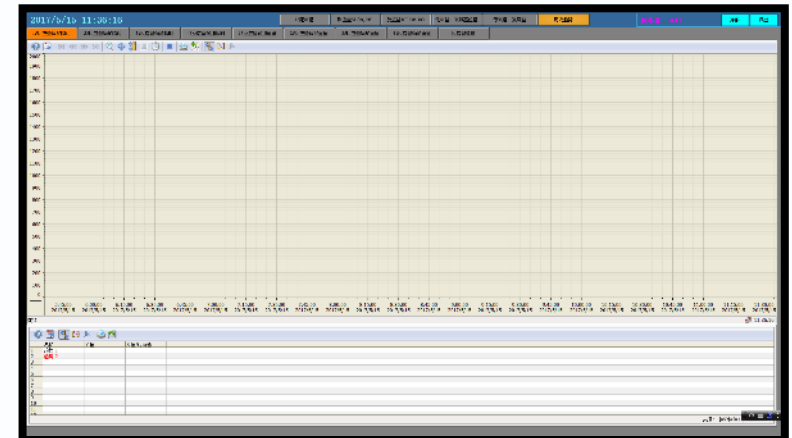
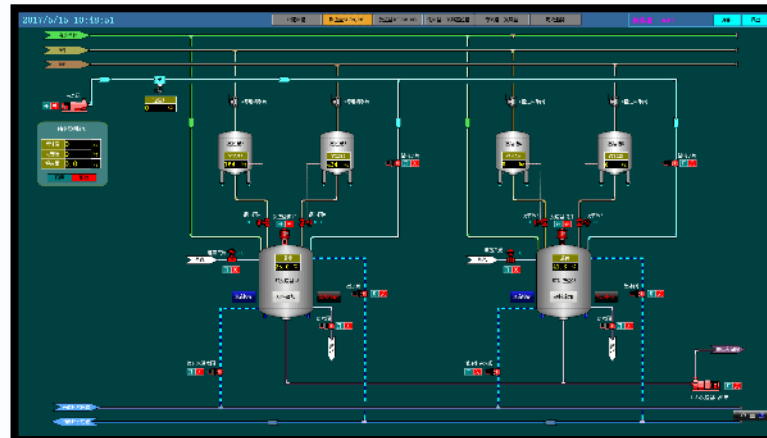
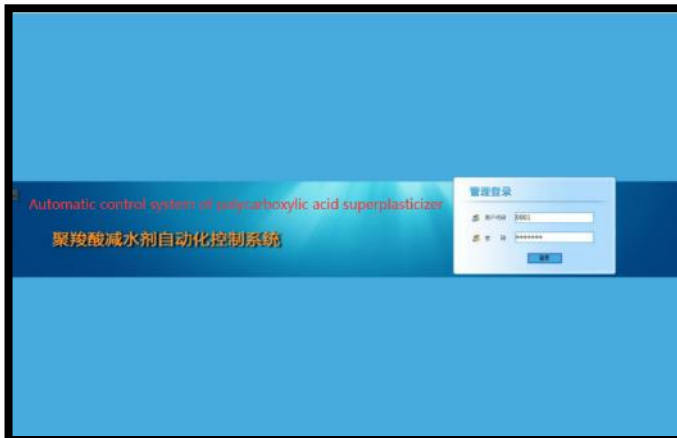

## Jinan Yu Ming Environmental protection Technology Co., LTD

01



## A cement factory in Jiangsu

02



03

Guangdong Jie construction  
Materials Co., LTD



04

Guangdong Shenjie Materials  
Technology Co., LTD

## 05

Zhangjiajie construction  
Co., Ltd



## 06

Henan Xingxiang  
concrete company

Guangdong Jiangmen  
construction Materials Co., Ltd.

07



Hunan yueyang yunxi Co.,Ltd.

08

